

# ServeRAID M5015 and M5014 SAS/SATA Controllers for IBM System x

## IBM System x at-a-glance guide

The ServeRAID M5015 and ServeRAID M5014 SAS/SATA Controllers for IBM System x are the next-generation 6 Gbps SAS 2.0 RAID controllers. The adapters have two internal mini-SAS connectors to control up to 32 devices and support global and dedicated hot-spare drives. The ServeRAID M5014 controller delivers a full RAID 6 Gbps SAS 2.0 solution, while the ServeRAID M5015 provides additional performance advantages of an extended cache and a standard battery backup unit. With the attachment of the ServeRAID M5000 Advanced Feature Key, the ServeRAID M5015 and M5014 offer the option of RAID 6, RAID 60, and SED Encryption Key management.

Figure 1 shows the ServeRAID M5015 with its standard battery backup unit.

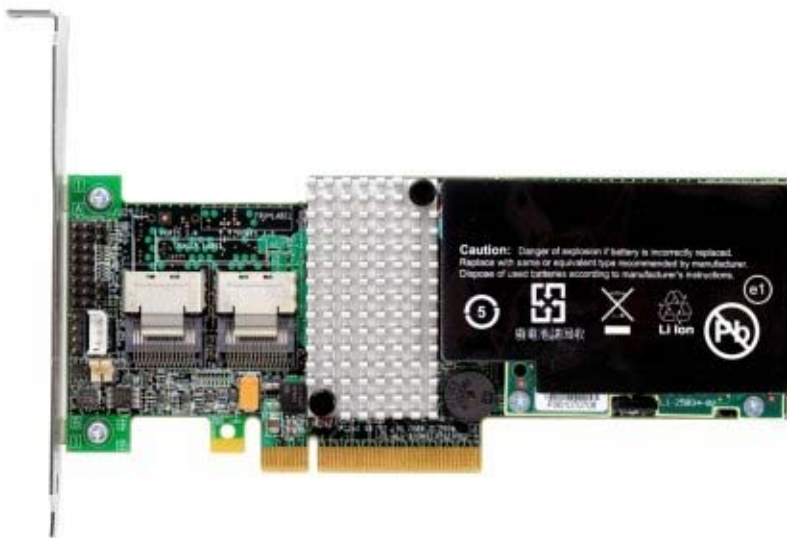

Figure 1. ServeRAID M5015 SAS/SATA Controller

### Did you know

6 Gbps SAS 2.0 technology has been introduced to address data off-load bottlenecks in the direct-access storage environment. This new throughput doubles the transfer rate of the previous generation. SAS 2.0 is designed for backward compatibility with 3 Gbps SAS as well as with 3 Gbps SATA hard drives.

Self-encrypting drives are based on a new technology that helps prevent data from being accessed without authorization. These drives adhere to the Trusted Computing Group (TCG) Enterprise Security Subsystem Class specification and are National Security Agency qualified to provide government-grade encryption. With self-encrypting drives (SEDs), if a drive is removed from its storage system or the server that it is housed in, the data on that drive is encrypted and useless to anyone who attempts to access it without the appropriate security authorization.

## Part number information

Table 1. Ordering part number and feature code

Description	Part number	Feature code
ServeRAID M5015 SAS/SATA Controller	46M0829	0093
ServeRAID M5014 SAS/SATA Controller	46M0916	3877
ServeRAID M5000 Series Advanced Feature Key	46M0930	5106
ServeRAID M5000 Series Battery Kit	46M0917	5744
ServeRAID M5000 Series Battery Remote Mount Cable	68Y7396	5862

The ServeRAID M5015 option part number includes the following items:

- One ServeRAID M5015 adapter card with full-height bracket
- One replaceable low-profile (2U) bracket
- One attached ServeRAID M5000 battery
- Documentation CD
- The IBM Important Notices Document

**Note:** The ServeRAID M5015 option part number 46M0829 includes the M5000 battery, however the feature code 0093 does not contain the battery. Order feature code 5744 if you wish to include the battery in the server configuration.

The ServeRAID M5014 option part number includes the following items:

- One ServeRAID M 5014 adapter card with full-height bracket
- One replaceable low-profile (2U) bracket
- The ServeRAID M V1.10 Utility and Documentation CD
- The IBM Important Notices Document

The ServeRAID M5000 Series Battery Kit option part number contains the following items:

- ServeRAID M5000 Battery
- Battery Flyer
- Quick Install Guide
- Important Notices Flyer

**Tip:** The Battery Remote Mount Cable is now a separately orderable item and is not part of the Battery Kit. The Remote Mount Cable is also included in the shipgroup of

## Specifications

The ServeRAID M5015 and ServeRAID M5014 adapter cards have the following specifications:

- Eight internal 6 Gbps SAS/SATA ports
- Two Mini-SAS internal connectors (SFF-8087)
- 6 Gbps throughput per port
- 800 MHz PowerPC processor with LSI SAS2108 6 Gbps RAID on Chip (ROC) controller

- x8 PCI Express 2.0 host interface
- Onboard data cache (DDR2 running at 800 MHz):
  - ServeRAID M5015: 512 MB
  - ServeRAID M5014: 256 MB
- Intelligent Li-Ion-based battery backup unit with up to 48 hours of data retention:
  - ServeRAID M5015: Standard in the option part number
  - ServeRAID M5014: Optional
- Supports RAID levels 0, 1, 5, 10, and 50 (RAID 6 and 60 support with the optional M5000 Advanced Feature Key)
- Connects to up to 32 SAS or SATA drives
- SAS and SATA drives are supported, but the mixing of SAS and SATA in the same RAID array is not supported
- Supports up to 64 logical volumes
- Supports LUN sizes up to 64 TB
- Configurable stripe size up to 1 MB
- Compliant with Disk Data Format (DDF) configuration on disk (COD)
- S.M.A.R.T. support



Figure 2. ServeRAID M5014 SAS/SATA Controller

## Features

The ServeRAID M5015 and ServeRAID M5014 adapter cards have the following features:

- Auto-resume on array rebuild or array reconstruction after loss of system power  
Auto-resume uses non-volatile NVRAM to save rebuild progress during a host reboot or power failure to automatically resume from the last checkpoint. Auto-resume will ensure data integrity is maintained through the process. The card supports a number of features that are able to be implemented without rebooting the server. Applications such as email and web server benefit from avoiding downtime during transition.
- Online Capacity Expansion  
Online Capacity Expansion (OCE) allows the capacity of a virtual disk to be expanded by adding new physical disks or making use of unused space on existing disks, without requiring a reboot.
- Online RAID Level Migration  
Online RAID Level Migration (also known as logical drive migration) provides the ability to migrate a virtual disk from any RAID level to any other RAID level without requiring a reboot. System availability and application functionality remain unaffected.
- Fast initialization for quick array setup
- Consistency check for background data integrity  
Consistency Check verifies that all stripes in a virtual disk with a redundant RAID level are consistent. The consistency check will mirror data when an inconsistent stripe is detected for a RAID 1 and recreating the parity from the peer disks when in the case of a RAID 5 or RAID 6. Consistency checks can be scheduled to take place periodically.
- Extensive online configuration options: advanced monitoring and event notification  
Management tools provide convenience for configuration of logical volumes plus alerting when errors have occurred or are about to occur.
- Patrol Read for media scanning and repairing  
Patrol read is a background sentry service designed to proactively discover and correct media defects (bad sectors) that arise normally as a disk drive ages. The service issues a series of verify commands and if a bad block is discovered, the card's firmware will use RAID algorithms to recreate the missing data and remap the sector to a good sector. The task is interruptible based on controller activity and host operations. The firmware also provides an interface where the patrol read task can be initiated, set up for continuous operation, and terminated from a management application. Patrol read can be activated by manual command or automatically.
- Global and dedicated Hot Spare with Revertible Hot Spare support:  
A hot spare rebuilds data from all virtual disks within the disk group in which it is configured. ServeRAID provides the ability to define a physical disk as a hot spare to replace a failed drive. Hot spares may be configured as either global or dedicated. A global hot spare allows any physical drive to be designated as a hot spare. A dedicated hot spare will allow the user to assign a hot spare drive to a particular array of the same drive type.

The ServeRAID M5000 Series Advanced Feature Key enables the following features:

- RAID levels 6 and 60
- LSI SafeStore: support for self-encrypting drive services:
  - Instant secure erase
  - Local key management

LSI SafeStore encryption services offer instant secure erase and local key management for self-encrypting drives. This technology represents a significant step forward in securing data on a disk drive from any unauthorized access or modification resulting from theft, loss, or repurposing of drives:

- Instant secure erase permanently removes data when repurposing or decommissioning SEDs.
- SafeStore local key management provides the necessary management and protection of SEDs using a simple pass phrase, security key identifier, and security key file that can be set and applied to all SEDs assigned to a ServeRAID adapter. This removes the complexity of managing each SED's unique encryption key, and essentially relieves the administrator from most of the daily tasks of securing data.

**Note:** To use the SED services of the ServeRAID M5000 Series Advanced Feature Key, you must use self-encrypting drives as listed in "Supported disk drives" below.

Figure 3 shows the ServeRAID M5000 Series Advanced Feature Key attached to the ServeRAID M5015 controller.

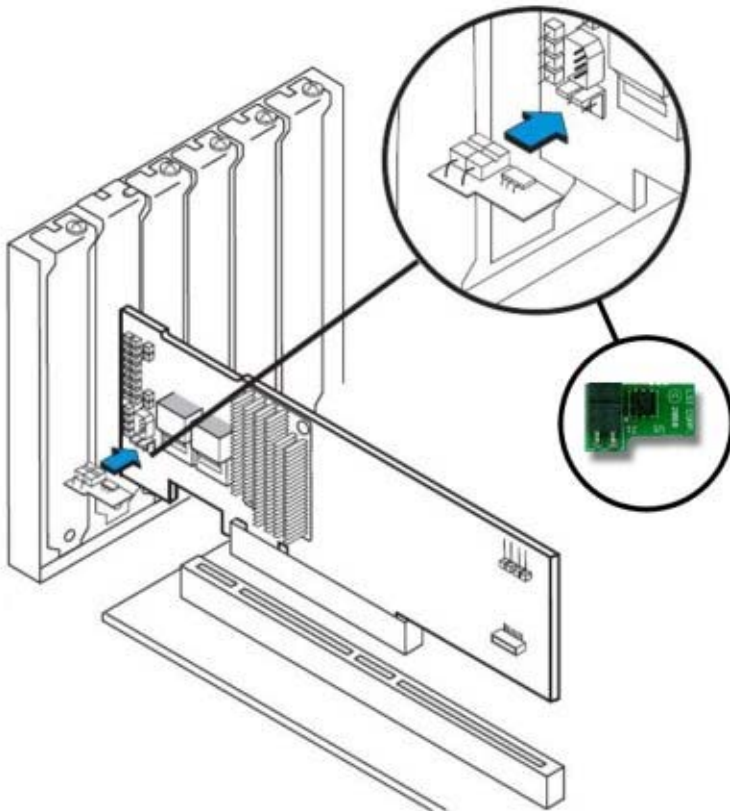

Figure 3. ServeRAID M5000 Series Advanced Feature Key

The ServeRAID M5000 Series Battery Remote Mount Cable is a 24-inch cable and enables the battery to be installed separately from the adapter.

## Operating environment

The ServeRAID M5015 and ServeRAID M5014 adapter cards are supported in the following environment:

- Temperature:
  - At 0-1000 m (0-3000 ft): 10-35° C (50-95° F)
  - At 1000-2100 m (3000-7000 ft): 10-32° C (50-90° F)
- Relative humidity: 20-80% (non-condensing)

## Supported servers

The ServeRAID M5015 and M5014 adapter cards are supported on the IBM System x servers listed in Table 2.

Table 2. Supported System x servers (Part 1)

Device	Part number	x3100 M3	x3200 M2	x3200 M3	x3250 M2	x3250 M3	x3350	x3400	x3400 M2	x3400 M3	x3455	x3500	x3500 M2	x3500 M3
ServeRAID M5015	46M0829	N	N	Y	N	Y	N	N	Y	Y	N	N	Y	Y
ServeRAID M5014	46M0916	N	N	Y	N	Y	N	N	Y	Y	N	N	Y	Y
ServeRAID M5000 Series Advanced Feature Key	46M0930	N	N	Y	N	Y	N	N	Y	Y	N	N	Y	Y
ServeRAID M5000 Series Battery Kit	46M0917	N	N	Y	N	Y	N	N	Y	Y	N	N	Y	Y
ServeRAID M5000 Series Battery Remote Mount Cable	68Y7396	N	N	N	N	N	N	N	N	N	N	N	N	N

Table 2. Supported System x servers (Part 2)

Device	Part number	x3550	x3550 M2	x3550 M3	x3620 M3	x3650	x3650 T	x3650 M2	x3650 M3	x3655	x3690 X5	x3755	x3850 M2	x3950 M2	x3850 X5
ServeRAID M5015	46M0829	N	Y	Y	Y	N	N	Y	Y	N	Y	N	N	N	Y
ServeRAID M5014	46M0916	N	Y	Y	Y	N	N	Y	Y	N	Y	N	N	N	Y
ServeRAID M5000 Series Advanced Feature Key	46M0930	N	Y	Y	Y	N	N	Y	Y	N	Y	N	N	N	Y
ServeRAID M5000 Series Battery Kit	46M0917	N	Y	Y	Y	N	N	Y	Y	N	Y	N	N	N	Y
ServeRAID M5000 Series Battery Remote Mount Cable	68Y7396	N	N	N	N	N	N	N	N	N	Y	N	N	N	N

See IBM ServerProven for the latest information on the System x servers that support each adapter:  
<http://ibm.com/servers/eserver/serverproven/compat/us/>

## Supported disk drives

The ServeRAID M5015 and M5014 adapter cards support the disk drives that are supported on the servers listed in Table 2. These drives and the servers that they are supported with are listed in the following tables.

Table 3. Supported hot-swap SAS drives

Part Number	Product Description	x3200 M3	x3250 M3	x3400 M2	x3400 M3	x3500 M2	x3500 M3	x3550 M2	x3550 M3	x3620 M3	x3650 M2	x3650 M3	x3850 X5
40K1042	36GB 15K Hot Swap SAS	N	N	N	N	N	N	N	N	N	N	N	N
40K1039	73GB 10K Hot Swap SAS	N	N	N	N	N	N	N	N	N	N	N	N
40K1043	73GB 15K Hot Swap SAS	N	N	Y	Y	N	Y	N	N	N	N	N	N
40K1040	146GB 10K Hot Swap SAS	N	N	N	N	N	N	N	N	N	N	N	N
40K1044	146GB 15K 3.5" Hot Swap SAS	Y	Y	Y	Y	N	Y	N	N	N	N	N	N
43W7524	146GB 15K 3.5" SAS Hot-Swap HDD	N	N	N	N	N	N	N	N	N	N	N	N
40K1041	300GB 10K 3.5" SAS Hot-Swap SAS	N	N	N	N	N	N	N	N	N	N	N	N
43X0802	300GB 15K 3.5" Hot-Swap SAS	N	N	Y	N	N	N	N	N	N	N	N	N
44W2234	IBM 300GB 15K 6Gbps SAS 3.5" HS HDD	Y	Y	Y	Y	Y	Y	N	N	Y	N	N	N
42D0519	IBM 450GB 15K SAS 3.5" HS HDD	N	N	Y	Y	N	Y	N	N	N	N	N	N
44W2239	IBM 450GB 15K 6Gbps SAS 3.5" HS HDD	Y	Y	Y	Y	Y	Y	N	N	Y	N	N	N
44W2244	IBM 600GB 15K 6Gbps SAS 3.5" HS HDD	Y	Y	Y	Y	Y	Y	N	N	Y	N	N	N
40K1051	36GB SFF 10K HS SAS	N	N	N	N	N	N	N	N	N	N	N	N
40K1052	73GB 10K 2.5" Hot-Swap SAS SFF	N	N	N	N	N	N	N	N	N	N	N	N
42D0672	IBM 73GB 15K 6Gbps SAS 2.5" SFF Slim-HS HDD	Y	Y	Y	Y	Y	Y	Y	Y	N	Y	Y	Y
43W7535	IBM 73 GB 10K SAS 2.5" SFF Slim-HS HDD	Y	Y	Y	N	Y	N	Y	N	N	Y	N	N
43W7545	IBM 73 GB 15K SAS 2.5" SFF Slim-HS HDD	N	N	Y	N	Y	N	Y	N	N	Y	N	N
43X0837	IBM Server 73GB SAS 15K 2.5" SFF HS	N	N	N	N	N	N	N	N	N	N	N	N
42D0617	IBM 146GB 10K 6Gbps SAS 2.5" SFF HS HDD	N	N	N	N	N	N	N	N	N	N	N	N
42D0632	IBM 146GB 10K 6Gbps SAS 2.5" SFF Slim-HS HDD	Y	Y	Y	Y	Y	Y	Y	Y	N	Y	Y	Y
42D0652	IBM 146GB 15K 6Gbps SAS 2.5" SFF HS HDD	N	N	N	N	N	N	N	N	N	N	N	N
42D0677	IBM 146GB 15K 6Gbps SAS 2.5" SFF Slim-HS HDD	Y	Y	Y	Y	Y	Y	Y	Y	N	Y	Y	Y
43W7536	IBM 146 GB 10K SAS 2.5" SFF Slim-HS HDD	N	N	Y	N	Y	N	Y	N	N	Y	N	N
43X0824	IBM Server 146GB SAS 10K 2.5" SFF HS	N	N	N	N	N	N	N	N	N	N	N	N
44W2294	IBM 146GB 15K 6Gbps SAS 2.5" SFF Slim-HS SED*	Y	Y	Y	Y	Y	Y	Y	Y	N	Y	Y	N
42D0612	IBM 300GB 10K 6Gbps SAS 2.5" SFF HS HDD	N	N	N	N	N	N	N	N	N	N	N	N
42D0637	IBM 300GB 10K 6Gbps SAS 2.5" SFF Slim-HS HDD	Y	Y	Y	Y	Y	Y	Y	Y	N	Y	Y	Y
44W2264	IBM 300GB 10K 6Gbps SAS 2.5" SFF Slim-HS SED*	Y	Y	Y	Y	Y	Y	Y	Y	N	Y	Y	N
49Y2003	IBM 600 10K 6Gbps SAS 2.5" Slim-HS HDD	Y	Y	Y	N	Y	N	Y	Y	N	Y	Y	N

\* SEDs require the ServeRAID M5000 Advanced Feature Key.

Table 4. Supported hot-swap NL SAS drives

Part Number	Product Description	x3200 M3	x3250 M3	x3400 M2	x3400 M3	x3500 M2	x3500 M3	x3550 M2	x3550 M3	x3620 M3	x3650 M2	x3650 M3	x3850 X5
42D0777	IBM 1TB 7.2K 6Gbps NL SAS 3.5" HS HDD	Y	Y	Y	N	Y	N	N	N	Y	N	N	N
42D0767	IBM 2TB 7.2K 6Gbps NL SAS 3.5" HS HDD	Y	Y	Y	N	Y	N	N	N	Y	N	N	N
42D0692	500GB 7200 6Gbps NL SAS 2.5" SFF HS HDD	N	N	N	N	N	N	N	N	N	N	N	N
42D0707	500GB 7200 6Gbps NL SAS 2.5" SFF Slim-HS HDD	N	N	Y	Y	Y	Y	Y	Y	N	Y	Y	Y

Table 5. Supported Simple Swap SAS drives

Part Number	Product Description	x3200 M3	x3250 M3	x3400 M2	x3400 M3	x3500 M2	x3500 M3	x3550 M2	x3550 M3	x3620 M3	x3650 M2	x3650 M3	x3850 X5
40K1045	Simple Swap 73GB 10K SAS HDD	N	N	N	N	N	N	N	N	N	N	N	N
40K1049	73GB 15K 3.5" Simple-Swap SAS	N	N	N	N	N	N	N	N	N	N	N	N
40K1046	Simple Swap 146GB 10K SAS HDD	N	N	N	N	N	N	N	N	N	N	N	N
40K1050	146GB 15K 3.5" Simple-Swap SAS	N	N	N	N	N	N	N	N	N	N	N	N
40K1047	300GB 10K 3.5" Simple-Swap SAS	N	N	N	N	N	N	N	N	N	N	N	N
43X0814	300GB 15K 3.5" Simple-Swap SAS	N	N	N	N	N	N	N	N	N	N	N	N

Table 6. Supported hot-swap SATA drives

Part Number	Product Description	x3200 M3	x3250 M3	x3400 M2	x3400 M3	x3500 M2	x3500 M3	x3550 M2	x3550 M3	x3620 M3	x3650 M2	x3650 M3	x3850 X5
39M4518	80GB Hot-Swap SATA II	N	N	N	N	N	N	N	N	N	N	N	N
41Y8204	80GB Hot-Swap SATA SystemSeller	N	N	N	N	N	N	N	N	N	N	N	N
39M4522	160GB 3.5" Hot-Swap SATA II	N	N	Y	N	N	N	N	N	N	N	N	N
41Y8208	160GB HS SATA II SystemSeller	N	N	N	N	N	N	N	N	N	N	N	N
39M4526	250GB 3.5" Hot-Swap SATA II	Y	Y	Y	Y	N	Y	N	N	Y	N	N	N
43W7598	250GB SATA HS 3GB/S HDD	N	N	N	N	N	N	N	N	N	N	N	N
39M4530	500GB Hot-Swap SATA II	Y	Y	Y	Y	N	Y	N	N	Y	N	N	N
39M4558	500GB 3.5" Dual Port Hot-Swap SATA II	N	N	N	N	N	N	N	N	N	N	N	N
40K6890	Cisco 500GB SATA Hot Swap HDD	N	N	N	N	N	N	N	N	N	N	N	N
41Y8226	Express 500GB HotSwap SATA II	N	N	N	N	N	N	N	N	N	N	N	N
41Y8232	Express 750GB HotSwap SATA II	N	N	N	N	N	N	N	N	N	N	N	N
43W7576	750GB Hot-Swap SATA II	Y	Y	Y	N	N	N	N	N	N	N	N	N
43W7580	750GB Hot-Swap SATA Dual Port	N	N	N	N	N	N	N	N	N	N	N	N
43W7584	750GB 7200rpm 3Gbps Hot Swap SATA HDD Cisco	N	N	N	N	N	N	N	N	N	N	N	N
43W7626	IBM Server 1TB 7200 SATA 3.5" HS HDD	Y	Y	Y	Y	N	Y	N	N	Y	N	N	N
42D0782	IBM 2TB 7200 SATA 3.5" HS HDD	Y	Y	Y	Y	Y	Y	N	N	N	N	N	N
42D0747	IBM 160GB 7200 NL SATA 2.5" SFF Slim-HS HDD	Y	Y	Y	Y	Y	Y	Y	Y	N	Y	Y	Y
43W7670	300GB 10K SATA 2.5" Slim-HS HDD	N	N	N	N	N	N	Y	N	N	Y	N	N
42D0752	IBM 500GB 7200 NL SATA 2.5" SFF Slim-HS HDD	N	N	Y	Y	Y	Y	Y	Y	N	Y	Y	Y



Table 7. Supported Simple Swap SATA drives

Part Number	Product Description	x3200 M3	x3250 M3	x3400 M2	x3400 M3	x3500 M2	x3500 M3	x3550 M2	x3550 M3	x3620 M3	x3650 M2	x3650 M3	x3850 X5
39M4500	80GB 7200 RPM 3.5" Simple Swap SATA HDD	N	N	N	N	N	N	N	N	N	N	N	N
39M4504	160GB 3.5" Simple-Swap SATA II	N	N	Y	N	N	N	N	N	N	N	N	N
39M4508	250GB 3.5" Simple-Swap SATA II	Y	Y	Y	Y	N	Y	N	N	Y	N	N	N
43W7594	250GB 7200-rpm Simple-swap SATA HDD	N	N	N	N	N	N	N	N	N	N	N	N
39M4514	500GB 3.5" Simple-Swap SATA II	Y	Y	Y	Y	N	Y	N	N	Y	N	N	N
41Y8207	Express 500GB Simple-Swap SATA II 3-Pack	N	N	N	N	N	N	N	N	N	N	N	N
41Y8218	Express 500GB SimpleSwap SATA II	N	N	N	N	N	N	N	N	N	N	N	N
41Y8222	Express 750GB SimpleSwap SATA II	N	N	N	N	N	N	N	N	N	N	N	N
43W7572	750GB Simple-Swap SATA II	Y	Y	Y	N	N	N	N	N	N	N	N	N
42D0787	IBM 2TB 7200 SATA 3.5" SS HDD	Y	Y	Y	Y	Y	Y	N	N	N	N	N	N

Table 8. Supported solid state drives

Part Number	Product Description	x3200 M3	x3250 M3	x3400 M2	x3400 M3	x3500 M2	x3500 M3	x3550 M2	x3550 M3	x3620 M3	x3650 M2	x3650 M3	x3850 X5
41Y8264	IBM 31.4GB SATA 2.5" SFF Slim-HS SSD V2	N	N	N	N	N	N	Y	N	N	Y	N	N
43W7714	IBM 50 SATA 2.5" SFF Slim-HS High IOPS SSD	N	N	N	N	N	N	Y	Y	N	Y	Y	Y
43W7722	IBM 50 SATA 2.5" SFF HS High IOPS SSD	N	N	N	N	N	N	N	N	N	N	N	N

## Warranty

One-year limited warranty. When installed on a System x server, these cards assume your system's base warranty and any IBM ServicePac upgrade. Batteries are consumables and therefore are not covered under the warranty.

## Supported operating systems

The ServeRAID M5015 and ServeRAID M5014 adapter cards support the following operating systems:

- Microsoft Windows Server 2003, Web Edition
- Microsoft Windows Server 2003/2003 R2, Datacenter Edition
- Microsoft Windows Server 2003/2003 R2, Datacenter x64 Edition
- Microsoft Windows Server 2003/2003 R2, Enterprise Edition
- Microsoft Windows Server 2003/2003 R2, Enterprise x64 Edition
- Microsoft Windows Server 2003/2003 R2, Standard Edition
- Microsoft Windows Server 2003/2003 R2, Standard x64 Edition
- Microsoft Windows Server 2008 R2
- Microsoft Windows Server 2008, Datacenter x64 Edition
- Microsoft Windows Server 2008, Datacenter x86 Edition
- Microsoft Windows Server 2008, Enterprise x64 Edition
- Microsoft Windows Server 2008, Enterprise x86 Edition
- Microsoft Windows Server 2008, Standard x64 Edition

- Microsoft Windows Server 2008, Standard x86 Edition
- Microsoft Windows Server 2008, Web x64 Edition
- Microsoft Windows Server 2008, Web x86 Edition
- Microsoft Windows Small Business Server 2003/2003 R2 Premium Edition
- Microsoft Windows Small Business Server 2003/2003 R2 Standard Edition
- Microsoft Windows WebServer 2008 R2
- Red Hat Enterprise Linux 4 AS for AMD64/EM64T
- Red Hat Enterprise Linux 4 AS for x86
- Red Hat Enterprise Linux 5 Server Edition
- Red Hat Enterprise Linux 5 Server Edition with Xen
- Red Hat Enterprise Linux 5 Server with Xen x64 Edition
- Red Hat Enterprise Linux 5 Server x64 Edition
- SUSE LINUX Enterprise Server 10 for AMD64/EM64T
- SUSE LINUX Enterprise Server 10 for x86
- SUSE LINUX Enterprise Server 10 with Xen for AMD64/EM64T
- SUSE LINUX Enterprise Server 11 for AMD64/EM64T
- SUSE LINUX Enterprise Server 11 for x86
- SUSE LINUX Enterprise Server 11 with Xen for AMD64/EM64T
- Solaris 10 Operating System
- VMware ESX 4.0
- VMware ESX 4.1
- VMware ESXi 4.0
- VMware ESXi 4.1

See the IBM ServerProven Web site for the latest information about the specific versions and service packs supported: <http://ibm.com/servers/eserver/serverproven/compat/us/>. Click **System x servers**, then **Disk controllers** to see the support matrix. Click the check mark that is associated with the System x server in question to see the details of the operating system support.

## Related publications

For more information refer to the following documents:

- IBM US Announcement Letter:  
<http://ibm.com/common/ssi/cgi-bin/ssialias?infotype=dd&subtype=ca&&htmlfid=897/ENUS109-416>
- IBM US Announcement Letter for the M5000 Series Advanced Feature Key:  
<http://ibm.com/common/ssi/cgi-bin/ssialias?infotype=dd&subtype=ca&&htmlfid=897/ENUS109-739>
- IBM US Announcement Letter for the M5000 Series Battery Remote Mount Cable:  
<http://ibm.com/common/ssi/cgi-bin/ssialias?infotype=dd&subtype=ca&&htmlfid=897/ENUS110-013>
- System x RAID products home page:  
[http://www.ibm.com/systems/storage/product/systemx/scsi\\_raid.html](http://www.ibm.com/systems/storage/product/systemx/scsi_raid.html)
- IBM ServeRAID software matrix:  
<http://www.ibm.com/support/docview.wss?uid=psg1SERV-RAID>
- IBM System x Configuration and Options Guide:  
<http://www.ibm.com/support/docview.wss?uid=psg1SCOD-3ZVQ5W>

# Notices

This information was developed for products and services offered in the U.S.A.

IBM may not offer the products, services, or features discussed in this document in other countries. Consult your local IBM representative for information on the products and services currently available in your area. Any reference to an IBM product, program, or service is not intended to state or imply that only that IBM product, program, or service may be used. Any functionally equivalent product, program, or service that does not infringe any IBM intellectual property right may be used instead. However, it is the user's responsibility to evaluate and verify the operation of any non-IBM product, program, or service. IBM may have patents or pending patent applications covering subject matter described in this document. The furnishing of this document does not give you any license to these patents. You can send license inquiries, in writing, to:

*IBM Director of Licensing, IBM Corporation, North Castle Drive, Armonk, NY 10504-1785 U.S.A.*

**The following paragraph does not apply to the United Kingdom or any other country where such provisions are inconsistent with local law:** INTERNATIONAL BUSINESS MACHINES CORPORATION PROVIDES THIS PUBLICATION "AS IS" WITHOUT WARRANTY OF ANY KIND, EITHER EXPRESS OR IMPLIED, INCLUDING, BUT NOT LIMITED TO, THE IMPLIED WARRANTIES OF NON-INFRINGEMENT, MERCHANTABILITY OR FITNESS FOR A PARTICULAR PURPOSE. Some states do not allow disclaimer of express or implied warranties in certain transactions, therefore, this statement may not apply to you. This information could include technical inaccuracies or typographical errors. Changes are periodically made to the information herein; these changes will be incorporated in new editions of the publication. IBM may make improvements and/or changes in the product(s) and/or the program(s) described in this publication at any time without notice.

Any references in this information to non-IBM Web sites are provided for convenience only and do not in any manner serve as an endorsement of those Web sites. The materials at those Web sites are not part of the materials for this IBM product and use of those Web sites is at your own risk. IBM may use or distribute any of the information you supply in any way it believes appropriate without incurring any obligation to you. Information concerning non-IBM products was obtained from the suppliers of those products, their published announcements or other publicly available sources. IBM has not tested those products and cannot confirm the accuracy of performance, compatibility or any other claims related to non-IBM products. Questions on the capabilities of non-IBM products should be addressed to the suppliers of those products. This information contains examples of data and reports used in daily business operations. To illustrate them as completely as possible, the examples include the names of individuals, companies, brands, and products. All of these names are fictitious and any similarity to the names and addresses used by an actual business enterprise is entirely coincidental.

Any performance data contained herein was determined in a controlled environment. Therefore, the results obtained in other operating environments may vary significantly. Some measurements may have been made on development-level systems and there is no guarantee that these measurements will be the same on generally available systems. Furthermore, some measurement may have been estimated through extrapolation. Actual results may vary. Users of this document should verify the applicable data for their specific environment.

## COPYRIGHT LICENSE:

This information contains sample application programs in source language, which illustrate programming techniques on various operating platforms. You may copy, modify, and distribute these sample programs in any form without payment to IBM, for the purposes of developing, using, marketing or distributing application programs conforming to the application programming interface for the operating platform for which the sample programs are written. These examples have not been thoroughly tested under all conditions. IBM, therefore, cannot guarantee or imply reliability, serviceability, or function of these programs.

**© Copyright International Business Machines Corporation 2009. All rights reserved.**

Note to U.S. Government Users Restricted Rights -- Use, duplication or disclosure restricted by GSA ADP Schedule Contract with IBM Corp.

This document was created or updated on January 25, 2011.

Send us your comments in one of the following ways:

- Use the online **Contact us** review form found at:  
[ibm.com/redbooks](http://ibm.com/redbooks)
- Send your comments in an e-mail to:  
[redbook@us.ibm.com](mailto:redbook@us.ibm.com)
- Mail your comments to:  
IBM Corporation, International Technical Support Organization  
Dept. HYTD Mail Station P099  
2455 South Road  
Poughkeepsie, NY 12601-5400 U.S.A.

This document is available online at <http://www.ibm.com/redbooks/abstracts/tips0738.html> .

## Trademarks

IBM, the IBM logo, and [ibm.com](http://ibm.com) are trademarks or registered trademarks of International Business Machines Corporation in the United States, other countries, or both. These and other IBM trademarked terms may also be registered or common law trademarks in other countries. A current list of IBM trademarks is available on the Web at <http://www.ibm.com/legal/copytrade.shtml>

The following terms are trademarks of the International Business Machines Corporation in the United States, other countries, or both:

IBM®  
PowerPC®  
Redpaper™  
Redbooks (logo)®  
ServerProven®  
ServicePac®  
System x®

The following terms are trademarks of other companies:

Microsoft, Windows Server, Windows, and the Windows logo are trademarks of Microsoft Corporation in the United States, other countries, or both.

Linux is a trademark of Linus Torvalds in the United States, other countries, or both.

Other company, product, or service names may be trademarks or service marks of others.