

# QLogic 8Gb FC Single-port and Dual-port HBAs for IBM System x

## IBM System x at-a-glance guide

The QLogic 8Gb FC Single-port and Dual-port HBA for IBM System x are PCI Express 2.0 x8 8Gb Fibre Channel adapters with SFP+ LC-style connectors. The adapters connect to SFP+ Multimode Fiber SR optical modules. These adapters support 8 Gbps per port maximum bidirectional throughput for high-bandwidth storage (SAN). The PCI Express low profile form factor adapter can be used in either a standard PCI Express slot or a low profile PCI Express slot. Figure 1 shows the adapters.

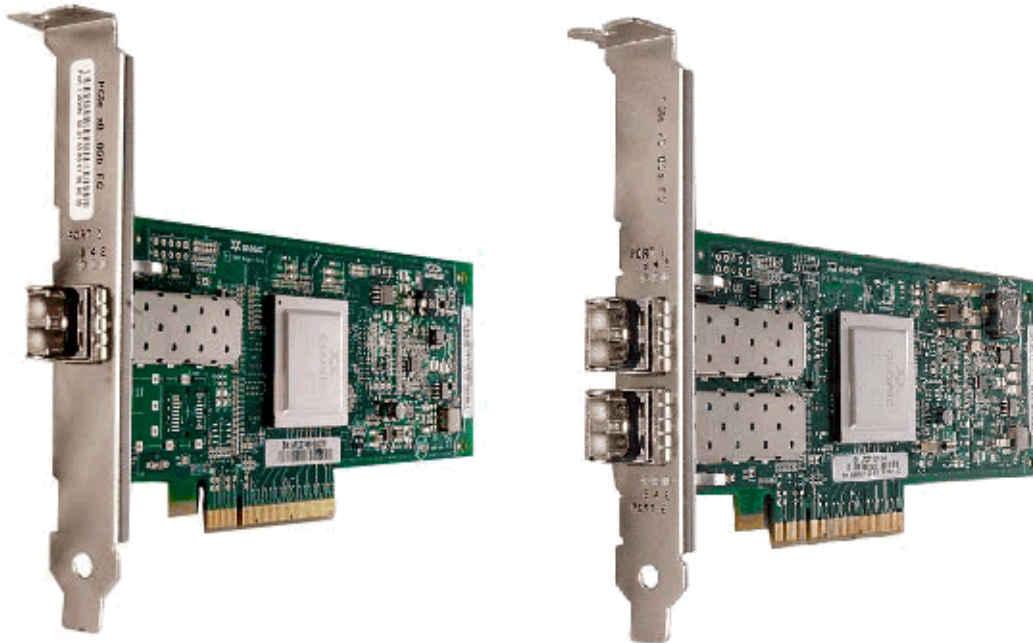

Figure 1. QLogic 8Gb FC Single-port and Dual-port HBAs for IBM System x

### Did You Know?

QLogic 8Gb HBAs enable end-to-end SAN Solutions using 8 Gb Fibre Channel technology for System x servers. They provide the ability to build high-performance, highly available SANs and are easy to set up and integrate into existing SAN configurations.

These adapters take advantage of QLogic's StarPower technology, which provides energy-smart features. StarPower technology offers dynamic and adaptive power-management features such as power-optimized and bandwidth-optimized intelligent PCI-Express link training, low-power switching power supplies, and a thermally efficient layout that requires lower airflows.

## Part number information

Table 1. Ordering part numbers and feature codes

Description	Part number	Feature code
QLogic 8Gb FC Single-port HBA for IBM System x	42D0501	3578
QLogic 8Gb FC Dual-port HBA for IBM System x	42D0510	3579

The part numbers for the QLogic 8Gb FC Single-port and Dual-port HBAs include the following items:

- One QLogic adapter
- Quick install guide
- Documentation CD
- 2U bracket
- Safety flyer

## Features

The QLogic 8Gb FC Single-port and Dual-port HBAs have the following features:

- Function at 8/4/2 Gbps (auto-negotiation)
- Persistent binding
- LUN masking
- 2,048 concurrent logins
- PCI Express 2.0 x8 compliance, backwards compatibility with PCI-e 1.0a
- One (for Single-port) and two (for Dual-port) SFP+ with LC-style connectors
- Standard PCI Express card with low profile MD2 form factor
- Support for both standard and low-profile PCI-E slots

## Specifications

The QLogic 8Gb FC Single-port and Dual-port HBAs have the following specifications:

- Data rate: 1600 MBps full duplex per port
- Performance: up to 200,000 IOPS per port
- Boot support: BIOS, FCode, UEFI, EFI
- Protocols: FCP-3-SCSI; FC-Tape (FCP-2)
- Standard supported: Enhanced Authentication (FC-SP), Data Integrity (T10) and Network isolation (NPIV)

## Physical specifications

The QLogic 8Gb FC Single-port and Dual-port HBAs have the following physical specifications:

- Height: 64 mm (2.5 in)
- Width: 167 mm (6.6 in)
- Depth: 25 mm (1.0 in)
- Weight: 113 g (0.25 lb)

## Operating environment

The adapter is supported in the following environment:

- Temperature:
  - Operating: 0° to 55°C (32° to 131°F) at 0 to 914 m (0 to 3,000 ft)
  - Storage: -40° to 70°C (-40° to 158°F) at 914 to 2,133 m (3,000 to 7,000 ft)
- Relative humidity:
  - Operating: 10% to 90% (relative, non-condensing)
  - Non-operating: 5% to 93% (relative, non-condensing)

## Warranty

One-year limited warranty. When installed in a System x server, these cards assume your system's base warranty and any IBM ServicePac upgrade.

## Supported servers

The QLogic 8Gb FC Single-port and Dual-port HBAs for IBM System x are supported in the IBM System x servers listed in Table 2.

Table 2. Supported System x servers (Part 1)

Adapter	Part number	x3100 M3	x3200 M2	x3200 M3	x3250 M2	x3250 M3	x3350	x3400	x3400 M2	x3400 M3	x3455	x3500	x3500 M2	x3500 M3
QLogic 8Gb FC Single-port HBA	42D0501	N	Y	Y	Y	Y	Y	Y	Y	Y	Y	Y	Y	Y
QLogic 8Gb FC Dual-port HBA	42D0510	N	Y	Y	Y	Y	Y	Y	Y	Y	Y	Y	Y	Y

Table 2. Supported System x servers (Part 2)

Adapter	x3550	x3550 M2	x3550 M3	x3620 M3	x3630 M3	x3650	x3650 T	x3650 M2	x3650 M3	x3655	x3690 X5	x3755	x3755 M3	x3850 M2	x3950 M2	x3850 X5
QLogic 8Gb FC Single-port HBA	Y	Y	Y	Y	Y	Y	N	Y	Y	Y	Y	Y	N	Y	Y	Y
QLogic 8Gb FC Dual-port HBA	Y	Y	Y	Y	Y	Y	N	Y	Y	Y	Y	Y	N	Y	Y	Y

See IBM ServerProven for the latest information on the System x servers that support this adapter:  
<http://ibm.com/servers/eserver/serverproven/compat/us/>

## Popular configurations

This section illustrates how the QLogic 8Gb FC Single-port and Dual-port HBAs can be used in configurations.

Figure 2 shows the QLogic 8Gb FC Dual-port HBAs installed in a supported x3650 M2 server. The server is connected to the IBM System Storage DS3400.

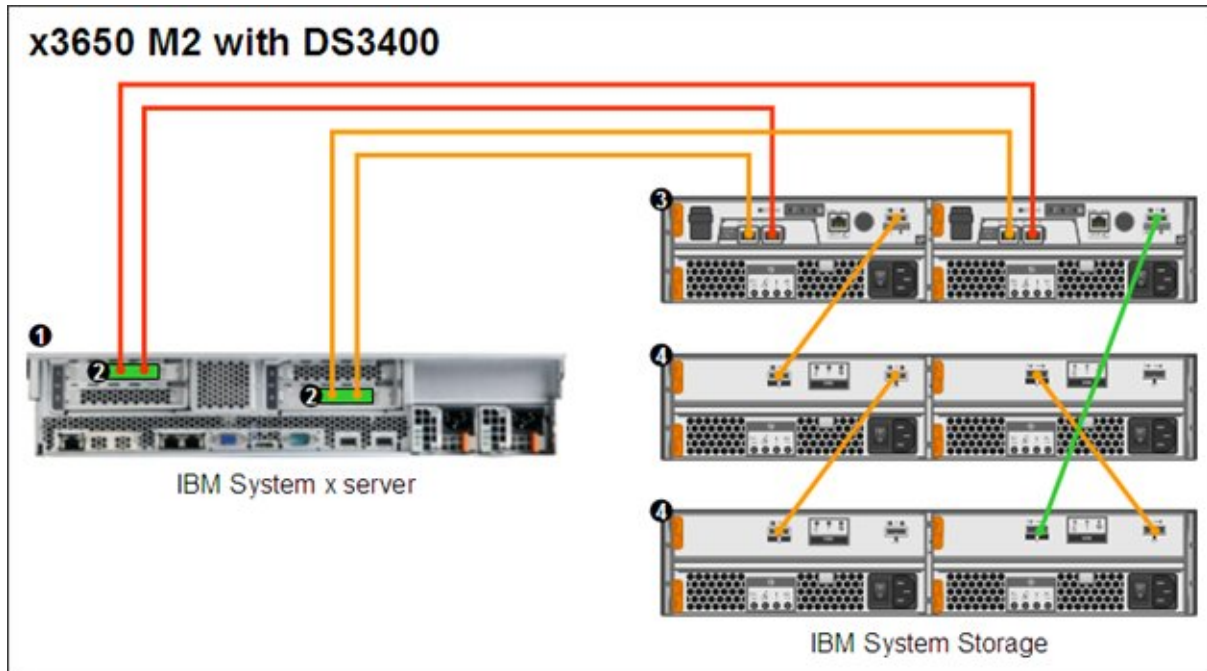

Figure 2. x3650 M2 server connected to an external IBM System Storage DS3400 storage solution

The parts used are listed in Table 3.

Table 3. Components used when connecting QLogic 8Gb FC Dual-port HBA to external disk storage (as shown in Figure 2)

Diagram reference	Part number/machine type	Description	Quantity
1	Varies	x3650 M2 or other supported server	1
2	42D0510	QLogic 8Gb FC Dual-port HBA	2 per server
3	1726-42X	IBM System Storage DS3400 ( Dual Controller)	1
4	1727	IBM System Storage EXP3000 (Dual ESM)	2

This configuration also requires cabling between the server and the storage and between the storage server and expansion units. (The cable part numbers are not listed in Table 3.)

Figure 3 shows the QLogic 8Gb FC Single-port HBAs installed in a supported x3650 M2 server. The servers are connected to the IBM System Storage DS4700 via IBM System Storage SAN24B-4 switches and form 2-node cluster solution.

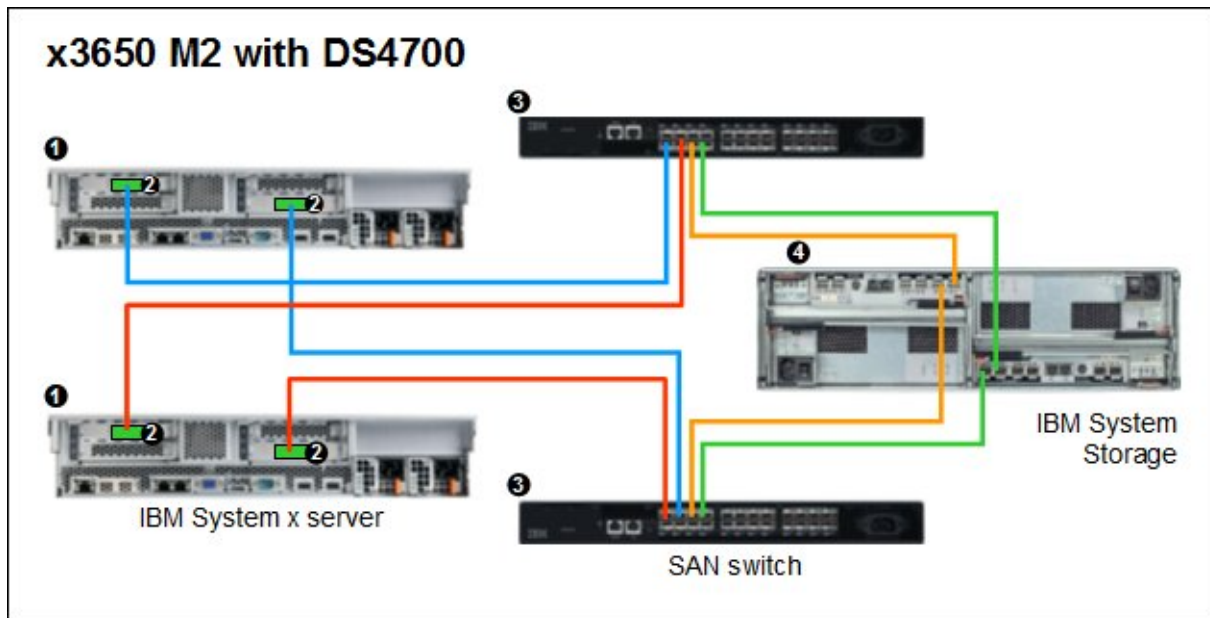

Figure 3. x3650 M2 server connected to an external IBM System Storage DS4700 via SAN switches

The parts used are listed in Table 4.

Table 4. Components used when connecting QLogic 8Gb FC Single-port HBA to external disk storage (as shown in Figure 3)

Diagram reference	Part number/machine type	Description	Quantity
1	Varies	x3650 M2 or other supported server	1
2	42D0501	QLogic 8Gb FC Single-port HBA	2 per server
3	Varies	IBM System Storage SAN24B-4 or other SAN switch	2
4	1814-70A or 1814-70H	IBM System Storage DS4700 (Model 70 or Model 72)	1

This configuration also requires cabling between the servers and the SAN switches and between the SAN switches and storage system. (The cable part numbers are not listed in Table 4.)

## Supported operating systems

The QLogic 8Gb FC Single-port and Dual-port HBAs for IBM System x support the following operating systems:

- Microsoft Windows Server 2003, Web Edition
- Microsoft Windows Server 2003/2003 R2, Datacenter Edition
- Microsoft Windows Server 2003/2003 R2, Datacenter x64 Edition
- Microsoft Windows Server 2003/2003 R2, Enterprise Edition
- Microsoft Windows Server 2003/2003 R2, Enterprise x64 Edition
- Microsoft Windows Server 2003/2003 R2, Standard Edition
- Microsoft Windows Server 2003/2003 R2, Standard x64 Edition
- Microsoft Windows Server 2008 R2
- Microsoft Windows Server 2008, Datacenter x64 Edition
- Microsoft Windows Server 2008, Datacenter x86 Edition
- Microsoft Windows Server 2008, Enterprise x64 Edition
- Microsoft Windows Server 2008, Enterprise x86 Edition
- Microsoft Windows Server 2008, Standard x64 Edition
- Microsoft Windows Server 2008, Standard x86 Edition
- Microsoft Windows Server 2008, Web x64 Edition
- Microsoft Windows Server 2008, Web x86 Edition
- Microsoft Windows Small Business Server 2003/2003 R2 Premium Edition
- Microsoft Windows Small Business Server 2003/2003 R2 Standard Edition
- Microsoft Windows Storage Server 2003/2003 R2, Standard Edition
- Microsoft Windows Storage Server 2003/2003 R2, Standard Edition x64
- Red Hat Enterprise Linux 4 AS for AMD64/EM64T
- Red Hat Enterprise Linux 4 AS for x86
- Red Hat Enterprise Linux 4 ES for AMD64/EM64T
- Red Hat Enterprise Linux 4 ES for x86
- Red Hat Enterprise Linux 4 WS/HPC for AMD64/EM64T
- Red Hat Enterprise Linux 4 WS/HPC for x86
- Red Hat Enterprise Linux 5 Server Edition
- Red Hat Enterprise Linux 5 Server x64 Edition
- SUSE LINUX Enterprise Server 10 for AMD64/EM64T
- SUSE LINUX Enterprise Server 10 for x86
- SUSE LINUX Enterprise Server 11 for AMD64/EM64T
- SUSE LINUX Enterprise Server 11 for x86
- SUSE LINUX Enterprise Server 11 with Xen for AMD64/EM64T
- SUSE LINUX Enterprise Server 9 for AMD64/EM64T
- SUSE LINUX Enterprise Server 9 for x86
- VMware ESX 3.5
- VMware ESX 4.0
- VMware ESXi 4.0
- VMware ESXi 4.1

See IBM ServerProven for the latest information about the specific versions and service packs supported: <http://ibm.com/servers/eserver/serverproven/compat/us/>. Click **System x servers**, and then click **Shared storage adapters** to see the support matrix. Click the check mark that is associated with the System x server in question to see the details of operating system support.

## Related publications

For more information refer to the following documents:

- QLogic 8Gb FC Single-port and Dual-port HBAs for IBM System x Data Sheet  
<ftp://ftp.software.ibm.com/common/ssi/pm/sp/n/xsd03042usen/XSD03042USEN.PDF>
- QLogic 8Gb FC Single-port and Dual-port HBAs for IBM System x Installation and User's Guide  
<http://www.ibm.com/support/docview.wss?uid=psg1MIGR-5076985>
- QLogic 8Gb FC Single-port and Dual-port HBAs for IBM System x product page  
<http://www.ibm.com/systems/storage/product/systemx/hba/8gbpcie.html>
- IBM US Announcement Letter for the QLogic 8Gb FC Single-port and Dual-port HBAs  
<http://ibm.com/common/ssi/cgi-bin/ssialias?infotype=dd&subtype=ca&&htmlfid=897/ENUS108-481>
- IBM System x Configuration and Options Guide  
<http://www.ibm.com/support/docview.wss?uid=psg1SCOD-3ZVQ5W>
- QLogic 8Gb FC Single-port and Dual-port HBAs for IBM System x driver download page  
[http://driverdownloads.qlogic.com/QLogicDriverDownloads\\_UI/Product\\_detail.aspx?oemid=376](http://driverdownloads.qlogic.com/QLogicDriverDownloads_UI/Product_detail.aspx?oemid=376)

# Notices

This information was developed for products and services offered in the U.S.A.

IBM may not offer the products, services, or features discussed in this document in other countries. Consult your local IBM representative for information on the products and services currently available in your area. Any reference to an IBM product, program, or service is not intended to state or imply that only that IBM product, program, or service may be used. Any functionally equivalent product, program, or service that does not infringe any IBM intellectual property right may be used instead. However, it is the user's responsibility to evaluate and verify the operation of any non-IBM product, program, or service. IBM may have patents or pending patent applications covering subject matter described in this document. The furnishing of this document does not give you any license to these patents. You can send license inquiries, in writing, to:

*IBM Director of Licensing, IBM Corporation, North Castle Drive, Armonk, NY 10504-1785 U.S.A.*

**The following paragraph does not apply to the United Kingdom or any other country where such provisions are inconsistent with local law:** INTERNATIONAL BUSINESS MACHINES CORPORATION PROVIDES THIS PUBLICATION "AS IS" WITHOUT WARRANTY OF ANY KIND, EITHER EXPRESS OR IMPLIED, INCLUDING, BUT NOT LIMITED TO, THE IMPLIED WARRANTIES OF NON-INFRINGEMENT, MERCHANTABILITY OR FITNESS FOR A PARTICULAR PURPOSE. Some states do not allow disclaimer of express or implied warranties in certain transactions, therefore, this statement may not apply to you. This information could include technical inaccuracies or typographical errors. Changes are periodically made to the information herein; these changes will be incorporated in new editions of the publication. IBM may make improvements and/or changes in the product(s) and/or the program(s) described in this publication at any time without notice.

Any references in this information to non-IBM Web sites are provided for convenience only and do not in any manner serve as an endorsement of those Web sites. The materials at those Web sites are not part of the materials for this IBM product and use of those Web sites is at your own risk. IBM may use or distribute any of the information you supply in any way it believes appropriate without incurring any obligation to you. Information concerning non-IBM products was obtained from the suppliers of those products, their published announcements or other publicly available sources. IBM has not tested those products and cannot confirm the accuracy of performance, compatibility or any other claims related to non-IBM products. Questions on the capabilities of non-IBM products should be addressed to the suppliers of those products. This information contains examples of data and reports used in daily business operations. To illustrate them as completely as possible, the examples include the names of individuals, companies, brands, and products. All of these names are fictitious and any similarity to the names and addresses used by an actual business enterprise is entirely coincidental.

Any performance data contained herein was determined in a controlled environment. Therefore, the results obtained in other operating environments may vary significantly. Some measurements may have been made on development-level systems and there is no guarantee that these measurements will be the same on generally available systems. Furthermore, some measurement may have been estimated through extrapolation. Actual results may vary. Users of this document should verify the applicable data for their specific environment.

## COPYRIGHT LICENSE:

This information contains sample application programs in source language, which illustrate programming techniques on various operating platforms. You may copy, modify, and distribute these sample programs in any form without payment to IBM, for the purposes of developing, using, marketing or distributing application programs conforming to the application programming interface for the operating platform for which the sample programs are written. These examples have not been thoroughly tested under all conditions. IBM, therefore, cannot guarantee or imply reliability, serviceability, or function of these programs.

**© Copyright International Business Machines Corporation 2009. All rights reserved.**

Note to U.S. Government Users Restricted Rights -- Use, duplication or disclosure restricted by GSA ADP Schedule Contract with IBM Corp.



This document was created or updated on September 9, 2010.

Send us your comments in one of the following ways:

- Use the online **Contact us** review form found at:  
[ibm.com/redbooks](http://ibm.com/redbooks)
- Send your comments in an e-mail to:  
[redbook@us.ibm.com](mailto:redbook@us.ibm.com)
- Mail your comments to:  
IBM Corporation, International Technical Support Organization  
Dept. HYTD Mail Station P099  
2455 South Road  
Poughkeepsie, NY 12601-5400 U.S.A.

This document is available online at <http://www.ibm.com/redbooks/abstracts/tips0721.html> .

## Trademarks

IBM, the IBM logo, and [ibm.com](http://ibm.com) are trademarks or registered trademarks of International Business Machines Corporation in the United States, other countries, or both. These and other IBM trademarked terms are US registered or common law trademarks owned by IBM at the time this information was published. Such trademarks may also be registered or common law trademarks in other countries. A current list of IBM trademarks is available on the Web at <http://www.ibm.com/legal/copytrade.shtml>

The following terms are trademarks of the International Business Machines Corporation in the United States, other countries, or both:

IBM®  
Redpaper™  
Redbooks (logo)®  
ServerProven®  
ServicePac®  
System Storage®  
System x®

The following terms are trademarks of other companies:

Microsoft, Windows, and the Windows logo are trademarks of Microsoft Corporation in the United States, other countries, or both.

Linux is a trademark of Linus Torvalds in the United States, other countries, or both.

Other company, product, or service names may be trademarks or service marks of others.